

PC2-COMP Express™

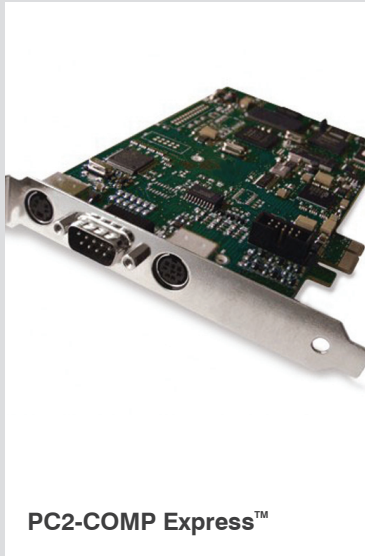

PC2-COMP Express™

Key Features

- Up to 6 composite colour or monochrome analog cameras
- Adaptive comb filter ensures superior image quality
- Real-time transfer to host enhances processing capabilities
- Robust application-specific software libraries speed time-to-market
- Teledyne DALSA Platform Development Advantage – Free Run-time Licensing¹

Overview

A PCI Express analog frame grabber

The PC2-COMP Express™ is a cost effective video capture board designed to meet the dynamic requirements of general-purpose video applications. Available as a half-size PCI Express x1 form factor board, the PC2-COMP Express offers a cost effective solution for a wide variety of application areas including video monitoring, medical visualization, surveillance, and machine vision applications. Its flexible acquisition front-end allows video capture from up to six colour or monochrome composite video or two S video cameras. Designed within Teledyne DALSA's field proven "Trigger-to-Image Reliability" framework, the PC2-COMP Express allows OEMs to bring high performance imaging solutions to market faster.

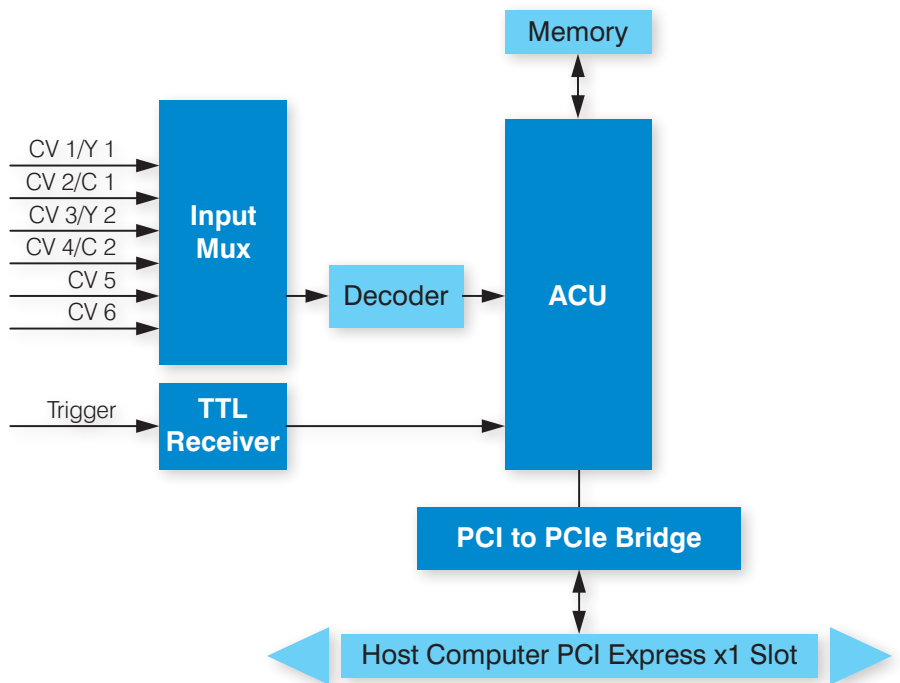

PC2-Comp Express—Functional Block Diagram

Teledyne DALSA Platform Development Advantage - Free Run-Time Licensing

The Spera Essential standard processing tool run-time license is offered at no additional charge when combined with the Teledyne DALSA frame grabbers. This software run-time license¹ includes access to over 400 image processing functions, area-based (normalized correlation based) template matching tool, blob analysis and lens correction tool.

¹ Some conditions and limitations apply, contact Teledyne DALSA sales for details.



PC2-COMP Express™

Video Capture

PC2-COMP Express offers multiplexed acquisition channels capable of acquiring video from NTSC/RS170 or PAL/CCIR cameras. Digitized images are transferred using on-board DMA to VGA display and system memory in real-time without loading the host computer resources.

Input Video Controls

For superior image acquisition, the PC2-COMP Express's highly adaptive programmable input filters offer brightness, contrast, hue, saturation, and sharpness controls. The programmable input gain controller allows automatic or manual adjustments.

Scale, Zoom, Invert, and Flip

The PC2-COMP Express features interpolated scale down by an arbitrary for the entire image or a region-of-interest. The input video can be flipped horizontally (image mirroring) or inverted vertically in real-time to maintain a consistent visual orientation. Image mirroring is an indispensable feature for teleconferencing, endoscopy, ophthalmology, and a variety of other image visualization applications.

Auxiliary Controls

PC2-COMP Express offers trigger input for external process synchronization. The TTL level trigger input is user programmable to work as a level or edge trigger input. In level-trigger mode, images are captured as long as trigger input remains active. Additionally, PC2-COMP Express takes full advantage of Sapera event notification messages like start/end-of-field/frame/odd/even/transfer, etc. to improve application response time.

Software Support

PC2-COMP Express supports Sapera Essential software development library under Windows XP Professional and Windows XP Professional 64-bit. Teledyne DALSA software development tools allow users to develop applications with C language DLLs, C++ classes, or ActiveX controls on Microsoft Visual C/C++ 6.0, Visual Basic 6.0 or Microsoft Visual Studio .Net or higher development platforms.

Notes:

1 Contact Teledyne DALSA Sales for more information

www.teledynedalsa.com

Specifications

Function	Description
Board	Half-slot PCI Express 1.0a compliant
Acquisition	6 Composite Video or 2 Y/C (4 CV and 1 YC OR 2 CV and 2 YC) Standard RS170, NTSC, CCIR, and PAL formats Up to 8MB of frame buffer memory Image mirroring and vertical flip Adaptive 2/4 line comb filter for high accuracy chrominance and luminance separation Arbitrary horizontal and vertical down scaling for randomly sized windows 0.7 VPP 75Ω terminated
Pixel Jitter	± 2ns
Pixel Formats	Pixel formats allow 8-bit mono, 16-bit YUV 4:2:2 packed and YUV 4:2:2 planar formats
Transfers	Simultaneous live image display and real-time transfers to system memory with no host CPU overhead DMA supports scatter-gather to optimize host frame buffer usage Allows on-the-fly camera switching with minimal frame loss
Controls	1 TTL Trigger Input Detects loss of input video signal Comprehensive event notification for start/end of odd/even field or frame signals required for application process synchronization
Software	Microsoft Windows XP Professional and Windows XP Professional 64-bit compliant Supports DirectDraw and TWAIN-32 Fully supported of Sapera LT Application development using C/C++ DLLs and ActiveX controls with Microsoft Visual Studio 6.0 and Microsoft Visual Studio .Net
System Requirement	Intel Pentium class CPU, 64MB system memory, 10MB free hard-drive space
Dimensions	PCI Express—6.677" (16.95 cm) Length x 4.20" (10.7cm) Height
Power	Max 1.8A at + 3.3V
Consumption	170mA at + 12V
Temperature	Operating 0°C (32° F) to +50° C (131° F) Storage -40°C (-40°F) to +125°C (257°F)
Relative Humidity	5% to 95% (non-condensing)
Markings	FCC-Approved CE-Approved

Americas

Boston, USA
Tel: +1 978-670-2000
sales.americas@teledynedalsa.com

Europe

Munich, Germany
Tel: +49 8142-46770
sales.europe@teledynedalsa.com

Asia Pacific

Tokyo, Japan
+81 3-5960-6353
sales.asia@teledynedalsa.com

Teledyne DALSA is an international leader in digital imaging and semiconductors and has its corporate offices in Waterloo, Ontario, Canada.

All trademarks are registered by their respective companies. Teledyne DALSA reserves the right to make changes at any time without notice. C0DS-1214 © Teledyne DALSA 2011

www.adept.net.au



TELEDYNE DALSA
A Teledyne Technologies Company