



adept electronic

**adept**  
**electronic solutions**

**The Machine Vision and  
Imaging Specialists**

Perth: +61 (08) 9242 5411  
Sydney: +61 (02) 9979 2599  
Melbourne: +61 (03) 9555 5621  
Email: [adept@adept.net.au](mailto:adept@adept.net.au)  
Web: <http://www.adept.net.au>



**iDS**



1280  
1024

**GigE uEye<sup>®</sup> UI-5540SE-M**

**1.3 Megapixels SXGA Camera with 1/2" CMOS Sensor**

## GigE uEye® SE UI-5540SE-M



### The GigE uEye® SE family

The GigE uEye® SE extends the broad range of uEye® industrial cameras by very compact models with Gigabit Ethernet interface, specially tailored to the needs of plant and machinery manufacturers. The bandwidth is 2.5 times higher than with USB and cable lengths up to 100 m are possible.

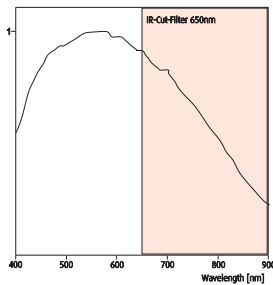

Sensor characteristics

UI-5540SE-M

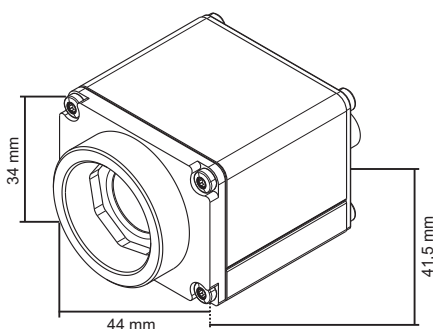

Dimensions GigE uEye SE CMOS-Model

### The characteristics at a glance

Interface	Gigabit Ethernet
Sensor Technology	CMOS
Model description (color)	-
Model description (Mono)	UI-5540SE-M
Resolution (h x v)	1280 x 1024
Resolution Category / Pixel Class	SXGA
Sensor size	1/2"
Shutter	Rolling
max. fps in Freerun Mode at full resolution	26,7 fps
max. fps in SW Trigger Mode at 1 ms exposure	22 fps
Exposuretime in Freerun Mode	35 µs - 4,9 s
Exposuretime in Trigger Mode	35 µs - 4,9 s
AOI Modes	H <sup>2</sup> + V <sup>2</sup>
AOI with 640 x 480 Pixels	247 fps
Subsampling Modes	H <sup>2</sup> + V <sup>2</sup> (color)
Subsampling Factors	x2, x4, x8
Resolution, fps	640 x 512, 94 fps 320 x 256, 260 fps 160 x 128, 522 fps
Binning Modes	-
Binning Method	-
Binning Factors	-
Resolution, fps	-
Mono: Maximum Gain	13x
Color: Maximum Gain RGB/Master	-
Additional Gain Boost with Factor	1,5x
Sensor Model	MT9M001
Pixel Clock	1 - 46 (59) MHz
Pixelpitch in µm	5,2
Full Well Capacity	40.000 e-
Optical Size	6,66 x 5,32 mm
Aspect Ratio	5:4
Exact Real Diagonal	8,5 mm, 1/1,9"

#### In scope of delivery:

Powerful, easy to handle uEye SDK  
uEye Demo and Programexamples  
executable and Source Code.  
uEye Camera Manager  
TWAIN, Active-X and Direct Show  
(WDM) drivers  
Interfaces for Activision Tools,  
Common Vision Blox, HALCON,  
LabVIEW and Neurocheck  
GenICam™ Interface

Driver for Windows 2000, XP, VISTA  
and Linux\*

² = Use increases frame rate

\* = in preparation