



adept electronic

adept electronic solutions

The Machine Vision and Imaging Specialists

Perth: +61 (08) 9242 5411
Sydney: +61 (02) 9979 2599
Melbourne: +61 (03) 9555 5621
Email: adept@adept.net.au
Web: <http://www.adept.net.au>



iDS

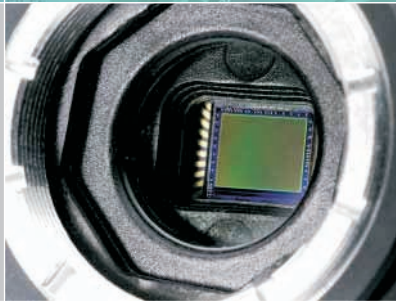

Gigabit Ethernet uEye® UI-5460-C

3,2 Mega pixels SUXGA Camera with 1/2" CMOS Sensor

Gigabit Ethernet uEye® UI-5460-C



The Gigabit Ethernet uEye® family

The Gigabit Ethernet uEye® extends the broad range of USB cameras by powerful models for sophisticated, complex machine vision and image processing applications. The bandwidth is 2.5 times higher than with USB and cable lengths up to 100 m are possible.

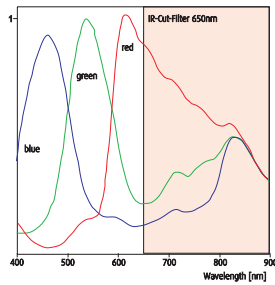

Sensor characteristics

UI-5460-C

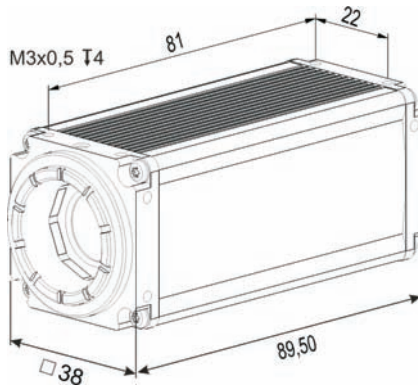

Dimensions of the Gigabit Ethernet uEye® models

Pin assignment MDR14 Multi I/O connector

Pin Notation	Description
1	GND
2	VCC
3	TriggerGND
4	TriggerIN
5	FlashOut
6	Vext
7	GND
8	GND
9	VCC
10	GPIO1
11	GPIO2
12	RxD
13	TxD
14	GND

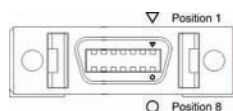

Power supply: 6 - 24V (12V recommended)

Connectors of the Gigabit Ethernet uEye® models



The characteristics at a glance

Interface	Gigabit Ethernet
Sensor Technology	CMOS
Model description (color)	UI-5460-C
Model description (Mono)	-
Resolution (h x v)	2048 x 1536
Resolution Category / Pixel Class	SUXGA/3,2 MP
Sensor size	1/2"
Shutter	Rolling
max. fps in Freerun Mode at full resolution	15 fps
max. fps in SW Trigger Mode at 1 ms exposure	14 fps
Exposuretime in Freerun Mode	41 µs - 1,75 s
Exposuretime in Trigger Mode	41 µs - 750 ms
AOI Modes	H ² + V ²
AOI with 320 x 240 Pixels (CIF)	112 fps
Subsampling Modes	H ² + V ²
Subsampling Factors	x2, x4
Resolution, fps	1024 x 768, 52 fps 512 x 384, 155 fps
Binning Modes	H ² + V ²
Binning Method	H: Sum V: Average
Binning Factors	x2, x4
Resolution, fps	1024 x 768, 42 fps 512 x 384, 72 fps
Mono: Maximum Gain	-
Color: Maximum Gain RGB/Master	7,25x/12x
Additional Gain Boost with Factor	2x
Sensor Model	MT9T001
Pixel Clock	5 - 60 MHz
Pixelpitch in µm	3,2
Full Well Capacity	20.000 e-
Optical Size	6,55 x 4,92 mm
Aspect Ratio	4:3
Exact Real Diagonal	8,2 mm, 1/2,0"

In scope of delivery:

Powerful, easy to handle uEye SDK
uEye Demo and Programexamples
executable and Source Code.
uEye Camera Manager
TWIN, Active-X and Direct Show
(WDM) drivers
Interfaces for Activision Tools,
Common Vision Blox, HALCON,
LabVIEW and Neurocheck
GenICam™ Interface*

² = Use increases frame rate
* = in preparation (end of 2007)

Driver for Windows 2000*, XP, VISTA*
and Linux*

