

Linea™ HS

32k CMOS TDI Camera

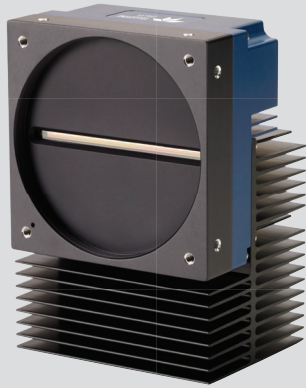

Key Features

- » 32k super resolution
- » High speed 150kHz
- » High sensitivity TDI
- » Bi-directionality
- » Assisted alignment marks

Programmability

- » Multiple Regions of Interest for calibration, data reduction
- » 8 bit output
- » Flat field and lens shading correction
- » Programmable coefficient sets

Typical Applications

- » Flat panel display inspection
- » Printed circuit board inspection
- » Semiconductor wafer
- » Life sciences
- » Web inspection
- » General purpose machine vision

Industry's First 32k TDI Camera with Improved Detectability

Based on Teledyne DALSA's industry leading CMOS TDI technology, the new Linea HS family offers advanced and unique TDI products. The Linea HS 32k camera is capable of capturing 32,768 pixel data using patent-pending pixel offset technology. This enables users to significantly improve subpixel defect detectability while using existing optical lenses and maintaining high sensitivity. The camera comes with high-speed fiber optic interface that delivers up to 8.4 GByte/sec data in a single cable and long cable length.

Patent Pending Pixel Offset Technology

The 32k camera uses two 16k/5 μm TDI arrays with $\frac{1}{2}$ pixel offset. Two 16k/5 μm image data are captured and then reconstructed to achieve a super resolution image of 32k/2.5 μm in real time. This significantly enhances detectability for subpixel defects. One advantage of the pixel offset technology is that existing 16k/5 μm lenses can be used without sacrifice in responsivity and MTF with a smaller physical pixel size.

Specifications

Resolution	32,768 x 64 pixels
Line rate	150 kHz maximum*
Pixel Size	5 x 5 μm / 2.5 x 2.5 μm
Bit depth	8 bit
Output	Monochrome
Lens Mounts	M90 x 1
Responsivity	see graph
Nominal Gain Range	1x to 10x
Size	97 x 140.5 x 78.6 mm
Mass	1200 g
Operating Temp	0 to +60 °C (frontplate)
Power Supply	+12 to +24 VDC
Power Dissipation	28 W
Data and Control	Camera Link HS CX4
GPIO	Hirose 12-pin
Regulatory Compliance	CE, FCC, RoHS

* Due to bandwidth limitation of the FG, max. line rate is 100 kHz

Camera Models

Part Number	Resolution	Max. Line Rate	Pixel Size	Output
HL-HM-32k15S-00-R	32,768 x 64 pixels	150 kHz*	5 x 5 μm 2.5 x 2.5 μm	Mono

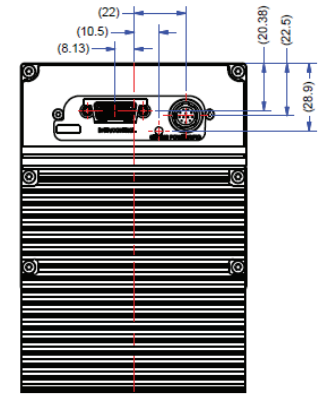
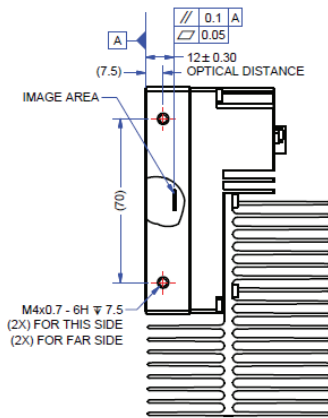
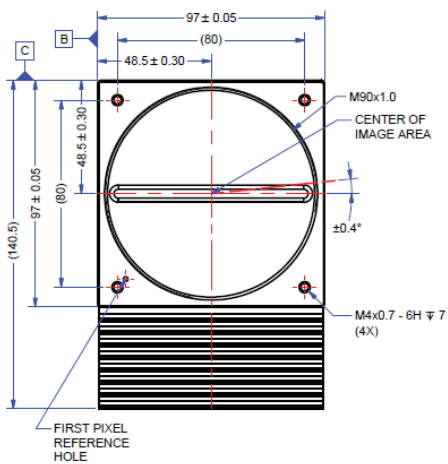
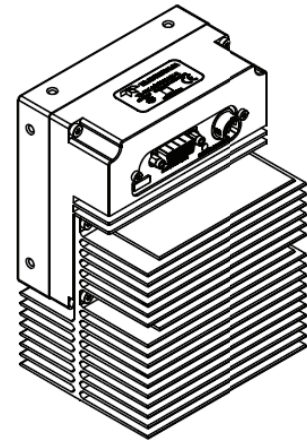
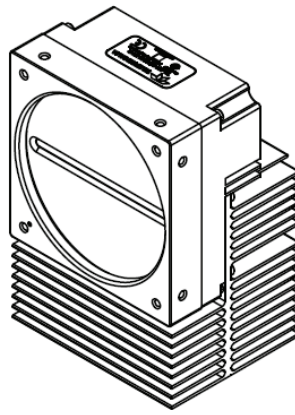
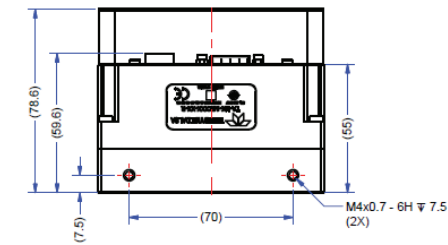
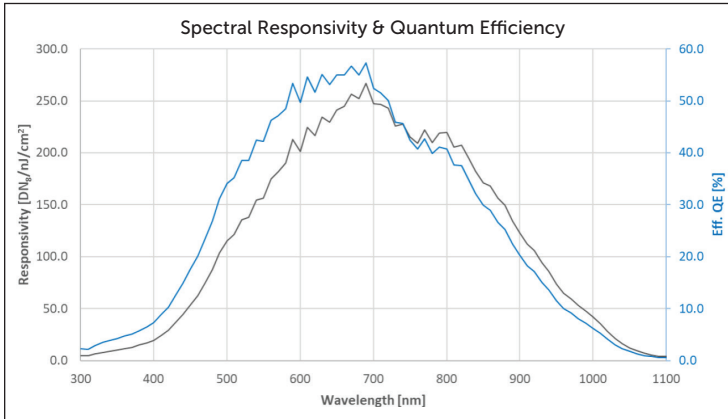

NOTES:
1. UNITS: MILLIMETERS.
2. IMAGE AREA IS ALIGNED TO DATUMS A, B & C.

Americas
Boston, USA
+1 978-670-2000
sales.americas@teledynedalsa.com

Europe
Krailling, Germany
+49 89-89-54-57-3-80
sales.europe@teledynedalsa.com

Asia Pacific
Tokyo, Japan
+81 3-5960-6353
sales.asia@teledynedalsa.com

Shanghai, China
+86 21-3368-0027
sales.asia@teledynedalsa.com