



Piranha HS HS-80-08Kx0

High Sensitivity Line Scan Cameras



Piranha HS HS-80-08Kx0

Key Features

- 8192 pixels
- 68 kHz line rate
- 320 / 640 megapixels/second
- Responsivity up to 1170 DN/(nJ/cm²)
- 15 second calibration time
- Bidirectional
- Antiblooming
- Configurable Medium or Full Camera Link

Programmability

- Stage selectability up to 96 stages
- Selectable area mode of operation for ease of alignment
- Up to four sets of flat field correction coefficients
- Mirroring and forward/reverse control
- Flat field corrections

Typical Applications

- Flat panel display inspection
- Postal sorting (flats)
- High performance document scanning
- Low light applications
- Large web applications

Overview

8k of resolution and 100X greater responsivity than traditional line scan cameras

The Piranha HS camera family represents DALSA's latest generation of high sensitivity, TDI based cameras. With a maximum line rate of 68 kHz and throughput up to 640 MHz, the Piranha HS 8k maximizes system throughput and provides the largest number of pixels available in a TDI camera. Camera alignment is also made easier with the selectable area mode of operation.

Camera configuration is extremely flexible and the number of Camera Link taps, throughput, and line rate are all software controllable.

All cameras are capable of bidirectionality with up to 96 stages of selectability, while preventing overexposure with antiblooming.

The HS 8k is available in two speed grades so you can select the best camera throughput for your application.

Specifications

Resolution	8192 x 96 TDI
Data Rate	320 / 640 megapixels/second
Max. Line/Frame Rate	34 / 68 kHz
Pixel Size	7 μ m
Data Format	8, 12 bit
Output	Med, Full Camera Link
Lens Mount	M72 x 0.75
Responsivity	1170 DN/(nJ/cm ²) broadband, 8 bit, 10 dB
Dynamic Range	56 dB
Nominal Gain Range	\pm 10 dB
Size	150 mm x 80 mm x 65 mm
Mass	<800 g
Operating Temp	0 °C to 50 °C
Power Supply	12 V to 15 V
Power Dissipation	<15 W (40 MHz) / <20 W (80 MHz)
Regulatory Compliance	CE and RoHS
Control	MDR26 Camera Link
Data	Shared with Control
Power	Hirose HR10 6 pin
Example Part Number	HS-80-08k80

Piranha HS HS-80-08Kx0

High Sensitivity Line Scan Cameras

These High Sensitivity Line Scan cameras use TDI technology to maximize photon capture at these high line rates. With data rates up to 640 MHz and 8k of resolution, these cameras inspect and detect with unrivalled precision and speed.

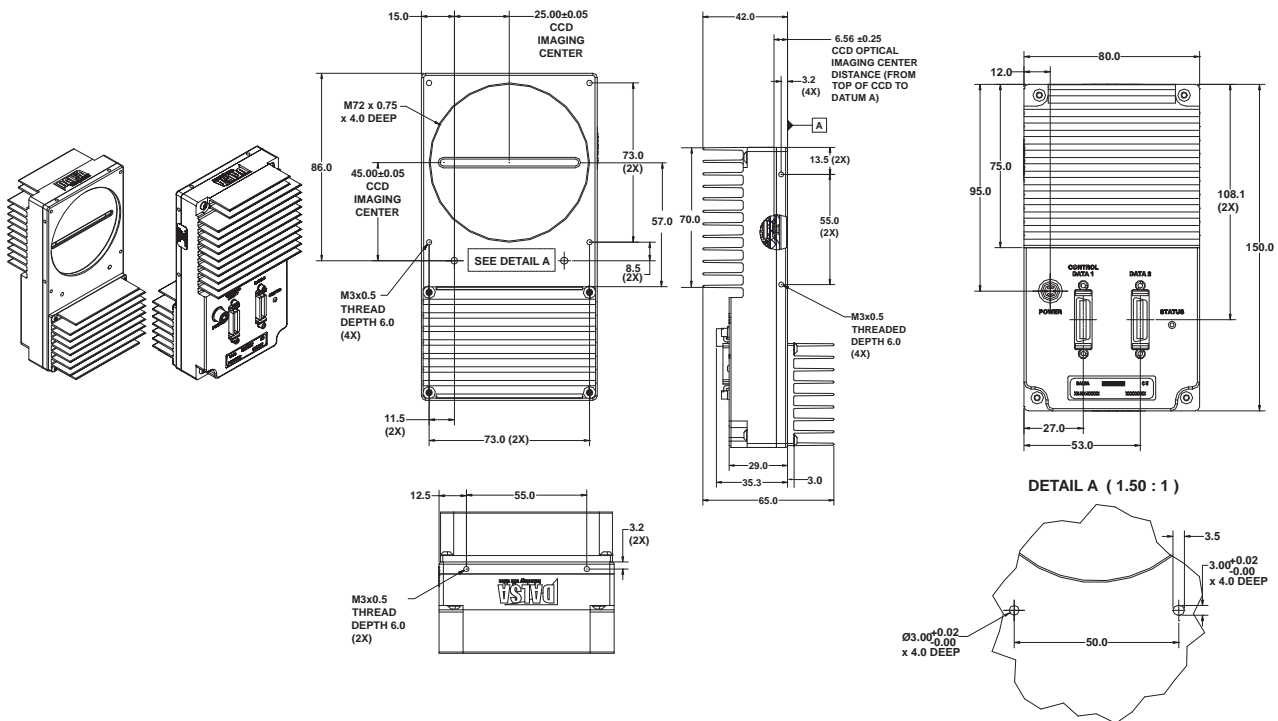
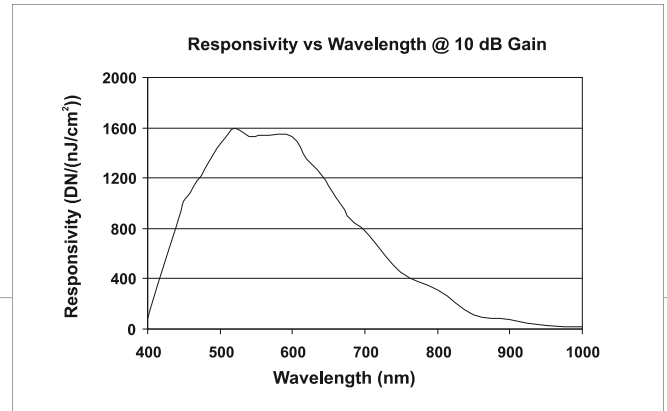

www.dalsa.com

Americas
Boston, USA
Tel: +1 978-670-2000
sales.americas@dalsa.com

Europe
Munich, Germany
Tel: +49 8142-46770
sales.europe@dalsa.com

Asia Pacific
Tokyo, Japan
+81 3-5960-6353
sales.asia@dalsa.com

DALSA is an international leader in digital imaging and semiconductors and has its corporate offices in Waterloo, Ontario, Canada.

All trademarks are registered by their respective companies. DALSA reserves the right to make changes at any time without notice. © DALSA 2008. piranha_HS_HS-80_102208

