



SMARTER IMAGING FOR BETTER LIVES

Perth: 08 9242 5411 Melbourne: 03 9384 1775

Sydney: 02 9905 5551

Email: [sales@adeptturnkey.com.au](mailto:sales@adeptturnkey.com.au)

Web: [www.adept.net.au](http://www.adept.net.au)



## Uniblitz® DSS35B

35mm Bi-Stable Optical Shutter

### Overview

The Uniblitz DSS35B is a 35mm bi-stable optical shutter that withholds an extremely low-profile construction. The device contains no external protruding components, making it very slim and flexible for system integration. The inherent reliability of the DSS35B comes from the fact that it contains only two moving parts: the drive ring and the blades. It is guaranteed to operate for 5,000,000 operations.

Bi-stable shutter devices, like the DSS35B, require no power to hold the blades in either the open or closed state.

### Key Features

- 35mm aperture
- Bi-stable operation
- **5M1P** and **5M1SM** adapters included
- **RoHS Compliant**
- Transfer time on opening:  
**23.0 milliseconds**
- Total opening time:  
**42.0 milliseconds**
- Configured for the **VED24 Shutter Driver**

# Product Options

**DSS35B** 2 3 4

Ex: DSS35B1T1

**1** Shutter Series:

- **DSS35B**

**2** Housing:

- **1:** Un-housed

**3** Blade Coating: <sup>1</sup>

- **T:** Low Energy (Teflon®)
- **ZM:** High Energy (AlMgF2) <sup>2</sup>

**4** Electronic Sync:

- **1:** Included

<sup>1</sup> Other blade coating options may be available by special order.

<sup>2</sup> Input side only; Teflon® coating is on opposite side to protect shutter blade surface. Light source must be input to the reflective side only.

# Shutter Timing

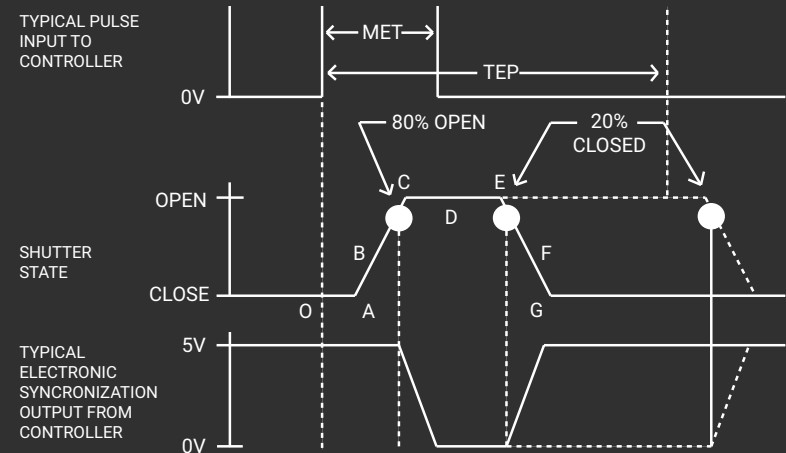

**DSS35B** (w/ VED24 and Teflon® coated blades)

**Time (msec.)**

O - A	Delay time on opening after current applied	19.0
A - C	Transfer time on opening	23.0
O - C	Total opening time	42.0
C - E	Min. dwell time with min. input pulse	23.5
B - F	Min. equivalent exp. time	45.0
D - E	Delay time on closing after current applied	18.0
E - G	Transfer time on closing	20.0
A - G	Total window time	66.0
MET	Min. exposure time	45.0
TEP	Typical exposure pulse	>45.0

# Technical Specifications

Coil Resistance	Voltage to Open	Hold Voltage
8 Ω	+10.7 VDC <sup>1</sup>	N/A

<sup>1</sup> Peak voltage as provided by the **VED24 Driver**

<sup>2</sup> (Continuous/Burst) Continuous frequency rating specified at shutter's minimum exposure pulse. Burst frequency rating specified for four (4) seconds maximum with one (1) minute minimum between bursts.

Series	Weight	Operating Temp.	Max. Opening Bounce	Max. Closing Bounce	Max. Freq. of Operation <sup>2</sup>	Number of Shutter Blades
DSS35B	1.92 oz (54.50 g)	-10 - +65 °C	15%	5%	1.5 Hz / 3.0 Hz	5

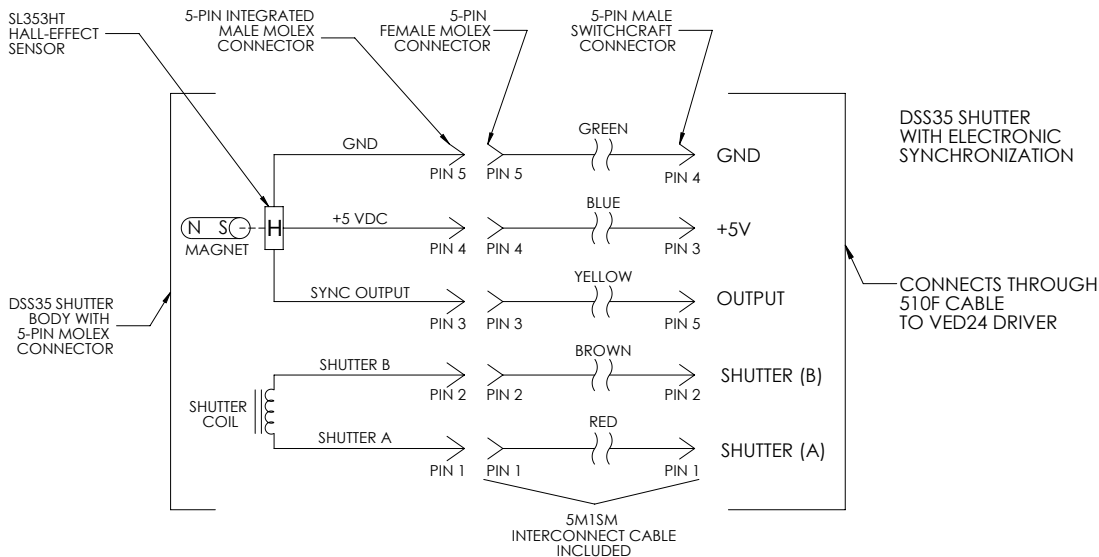

The synchronization system for DSS35B shutter devices incorporates a small magnet mounted to the driving mechanism and a Hall effect sensor. When the device achieves approximately 80% of full open, the magnet causes the Hall effect sensor to change state, producing a signal to indicate that the shutter has switched to the active state. Shown to the left is the DSS35B's shutter schematic which incorporates this electronic synchronization system.

# Technical Specifications - Included Adapters

## 5M1SM

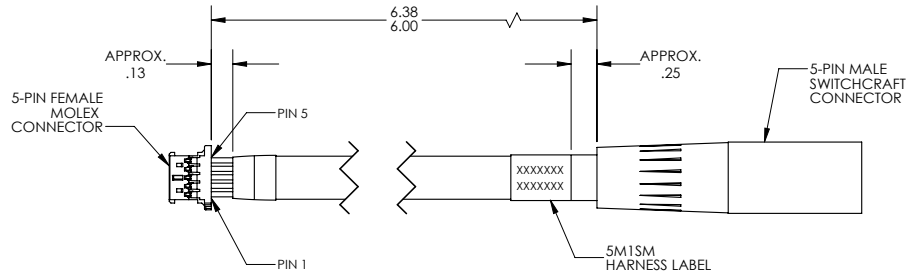

## 5M1P

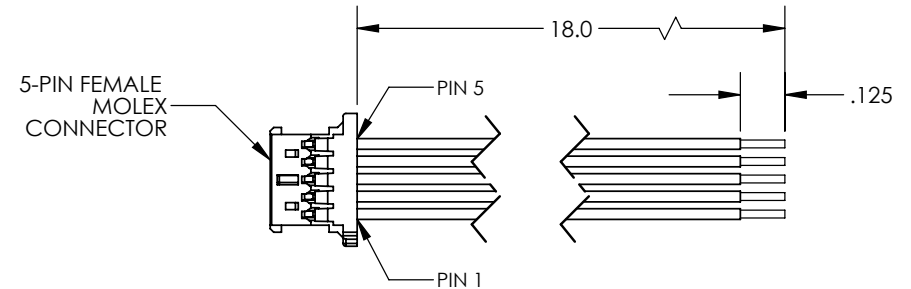

Molex (F) Pin	Signal	SwitchCraft (M) Pin
1	Shutter (+)	1
2	Shutter (-)	2
3	Sync Output (+)	5
4	+5 VDC Reg. (Sync)	3
5	Ground	4

Molex (F) Pin	Wire Color	Signal
1	Red	Shutter (+)
2	Brown	Shutter (-)
3	Yellow	Sync Output (+)
4	Blue	+5 VDC Reg. (Sync)
5	Green	Ground

# Technical Drawings - DSS35B

