

## CV-L107 CL

3 CCD RGB Line Scan Camera



- 3 CCD line scan camera with Camera Link output
- Dichroic RGB beam splitter prism with 3 sensors
- 3 sensors with 2048 pixels, 14  $\mu\text{m}$  x 14  $\mu\text{m}$
- 28.7 mm scanning width
- Video output in Camera Link: 24 bit in base configuration. 30 bit in medium
- Scan rate up to 19048 lines per second at 40 MHz pixel clock
- Edge pre-select and pulse width trigger modes
- One-push auto white balance
- Two point flat-field and shading correction
- Knee and binning functions for extended dynamic
- Built-in diagnostics
- Lens adapter for Nikon F-mount or P-mount (M42x1)
- Short ASCII commands set-up via RS 232C or Camera Link
- Setup by Windows NT/2000/XP software



# Specifications for CV-L107 CL

Specifications	CV-L107 CL
Scanning system	Line sensor with internal clock
Pixel clock	40.00 MHz
Scan rate	Max. 19048 lines/second (2100 pixels per line)
Sensor	3 line sensors mounted on RGB beam splitter prism
Sensor scanning width	28.7 mm
Cell size	14 (h) x 14 (v) $\mu\text{m}$
Active pixels	3 x 2048 (h) 3 x 1024 (h) with 2:1 binning
Sensitivity	7.5 mV/nl/cm <sup>2</sup> (Gain 0 dB, 525 $\mu\text{s}$ exp., 100% video on G)
Sensitivity	162 Lux (Gain 0 dB, 525 $\mu\text{s}$ exp., 100% video on G)
S/N ratio	58 dB on green with gain = -3 dB
Video output	24 bit in CL base configuration 30 bit in CL medium configuration
Gain	Master (G). -3 dB to +12 dB R and B. -9 dB to +9 dB
White balance	Manual, fixed or one-push Adjustable range 2800 K to 9000 K Fixed: 3900 K, 4600 K or 5600 K
Knee function	Individual RGB knee point and slope
Shading correction	Individual RGB flat or RB to G (One-push. Range -20%)
Flat-field correction	Two point pixel-to-pixel correction
Synchronization	Internal X-tal or external trigger
Trigger modes	No-shutter, shutter-select and pulse width control
Scan rate	Internal generator 18.6 to 19048 lines/sec. in 1024 steps. External trigger pulse up to 19048 lines/sec.
Programmable exposure	50 nsec. to 53.8 msec. in 25 ns increments
Functions controlled by RS 232C or CL	Trigger modes, scan rate, exposure time, gain/black level, shading correction, flat-field correction, white balance, knee-function, diagnostics
Diagnostics	Test pattern. (Color bar, gray pattern and white) LED for power
Lens mount	Nikon F-mount. (Standard) P-mount (M42x1) (Optional)
Sensor alignment	Better than $\pm 0.1$ pixel
Operating temperature	-5°C to +45°C
Humidity	20 – 80% non-condensing
Storage temp./humidity	-25°C to +60°C/20 – 80% non-condensing
Vibration	3G (20Hz to 200Hz, XYZ direction)
Shock	50G
Regulations	CE (EN50081-1 and EN50082-2) IEC61000-4-2 Conforming level 4 FCC Part15 Class B RoHS
Power	12V DC $\pm$ 10%. 15W
Dimensions (H x W x D)	90 mm x 90 mm x 90 mm
Weight	860 g

## Ordering Information

CV-L107 CL. 3 CCD RGB Line Scan Camera. F-mount.  
CV-L107 CL. 3 CCD RGB Line Scan Camera. P-mount (M42 x 1 thread).

## Connection Pin-out

### DC In / Trigger

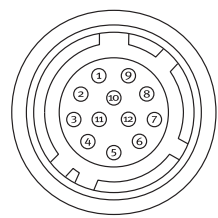

HIROSE HR10A-10R-12PB-01

Pin	Signal	Function
1	Ground	
2	+12V DC	
3	Ground	
4	Reserved	
5	Ground	
6	RXD RS 232C*	
7	TXD RS 232C*	
8	Ground	
9	XEEN output	
10	Trigger input (TTL)*	
11	+12V DC	
12	Ground	

### Camera Link Interface

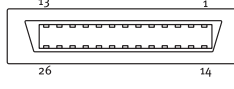

Pin	Signal	Function	
1	14	GND	
2	15	X0-/X0+	CL Data
3	16	X1-/X1+	CL Data
4	17	X2-/X2+	CL Data
5	18	Xclk-/Xclk+	CL Clk
6	19	X3-/X3+	CL Data
7	20	SerTC+/SerTC- Serial in *	
8	21	SerTFG-/SerTFG+ Serial out *	
9	22	CC1-/CC1+	Trigger *
10	23	CC2-/CC2+	Not used
11	24	CC3-/CC3+	Not used
12	25	CC4-/CC4+	Not used
13	26	GND	

\* In Camera Link or 12 pin Hirose  
**Note:**  
Camera Link base configuration shown.  
For medium configuration refer to Camera Link specifications or operation manual.

## Spectral Response

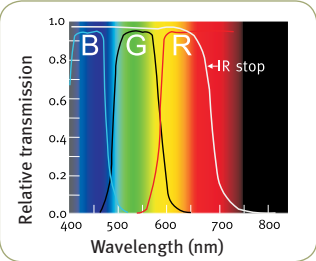

## Dimensions

### Front view

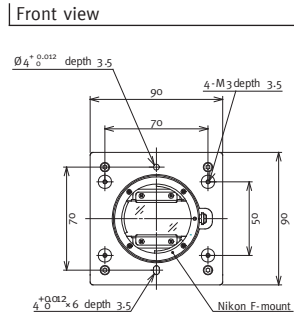

### Side view

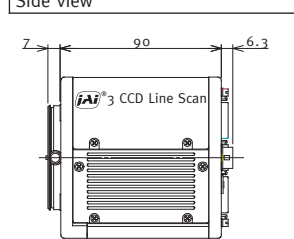

### Bottom view

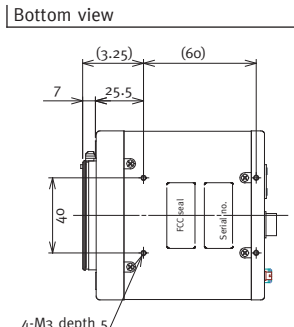

### Rear view

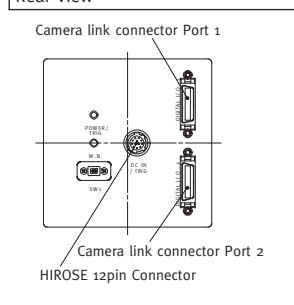

Company and product names mentioned in this datasheet are trademarks or registered trademarks of their respective owners. JAI AS cannot be held responsible for any technical or typographical errors and reserves the right to make changes to products and documentation without prior notification.

Europe, Middle East & Africa  
Phone +45 4457 8888  
Fax +45 4491 8880

Asia Pacific  
Phone +81 45 440 0154  
Fax +81 45 440 0166

Americas  
Phone (Toll-Free) 1 800 445 5444  
Phone +1 408 383 0300

Visit our web site on [www.jai.com](http://www.jai.com)

  
See the possibilities

31014603.06.07.3000