

Spyder Color CL Preliminary

Dual Line Scan Color Cameras



Key Features

- 2k and 4k resolutions
- RGB, RG/BG, or G output formats
- Antiblooming and exposure control
- Pre-calibrated light sources
- Cost-effective, easy-to-use
- Camera Link configuration

Programmability

- Automatic white balance
- Color correction
- Bidirectional
- Flat field correction

Typical Applications

- Wood, tile, and paper inspection
- Cotton and textile
- Food, drug, and tobacco inspection
- Recycling sorting
- General machine vision

Overview

Low-cost, ease of use, flexibility.

DALSA's Spyder Color CL is a color line scan camera based on the successful Spyder 3 dual line scan monochrome model. This camera provides high color fidelity, flexibility, and a low cost solution.

The Spyder Color CL has the red and blue color pixels alternating in one line and all the green pixels in the other line with no spacing between the lines. The camera offers several color output format options, including RGB, RG/BG, or G only to meet different imaging requirements.

This camera also incorporates advanced features such as flat field correction, automatic white balance, and is pre-calibrated to light sources such as white LEDs, for ease of use.

Specifications

Resolution	2048 x 2 / 4096 x 2
Data Rate	80 megapixels per second
Max. Line/Frame Rate	18 / 9 kHz
Pixel Size	14 x 14 μm / 10 x 10 μm
Data Format	8, 12 bit, selectable
Output	Camera Link
Lens Mount	M42 x 1, C, F
Responsivity	700 / 400 DN(nJ/cm ²)@0dB, 12 bit
Dynamic Range	60 dB
Nominal Gain Range	± 10 dB
Size	72 x 60 x 50 mm (2k) / 85 x 65 x 50mm (4k)
Mass	300 g
Operating Temp	0 °C to 50 °C
Power Supply	+12 V to +15 V
Power Dissipation	<9 W
Regulatory Compliance	CE and RoHS
Control	MDR26 female Camera Link
Data	Shared with control
Power	Hirose 6 HR10 pin male
Example Part Number	SC-30-0xk80-00-R

Spyder Color CL Preliminary

Dual Line Scan Color Cameras

The Spyder Color Camera Link is a cost-effective and easy-to-use bilinear color linescan camera.

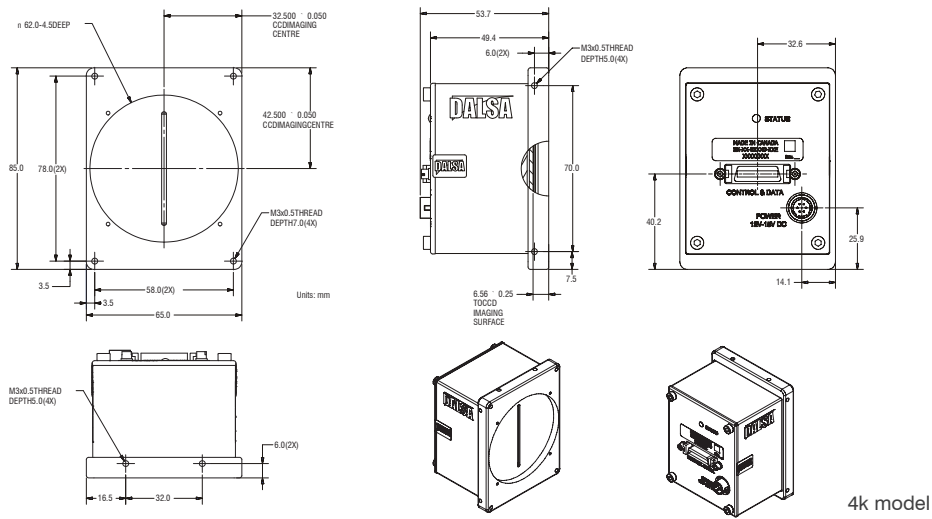
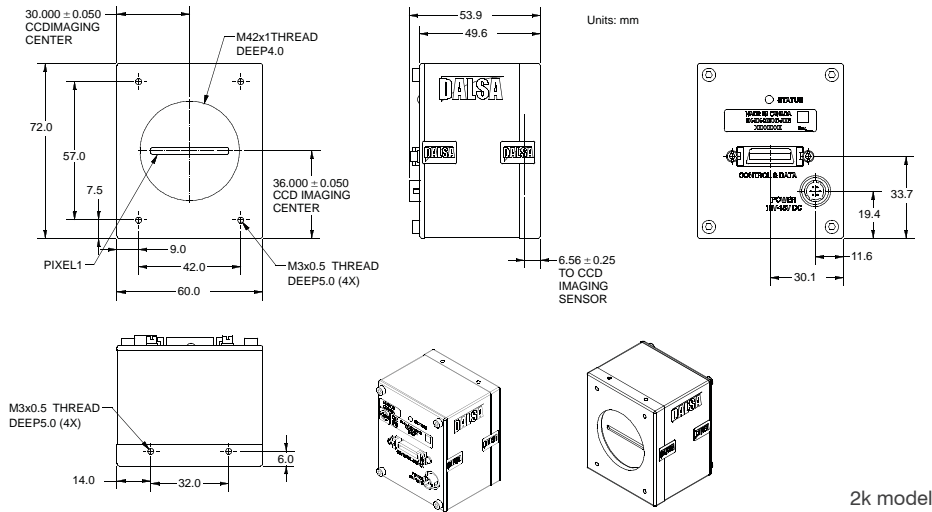
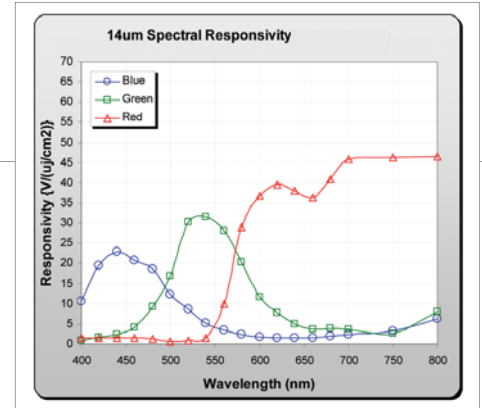

www.dalsa.com

Americas
 Boston, USA
 Tel: +1 978-670-2000
 sales.americas@dalsa.com

Europe
 Munich, Germany
 Tel: +49 8142-46770
 sales.europe@dalsa.com

Asia Pacific
 Tokyo, Japan
 +81 3-5960-6353
 sales.asia@dalsa.com

DALSA is an international leader in digital imaging and semiconductors and has its corporate offices in Waterloo, Ontario, Canada.

All trademarks are registered by their respective companies. DALSA reserves the right to make changes at any time without notice. © DALSA 2008. spyder_3_color_cl_sc-30-0-xx80_102108

