



AVT Stingray F-504B / F-504C AVT Stingray F-504B / F-504C fiber



Stingray. The Transformer Camera

The Stingray falls into the mid-range in terms of price, but offers a breadth of functions unrivaled in its class and an unbeatable price/performance ratio. The eight different versions are equipped with a fast FireWire IEEE1394b interface and high-end CCD sensors in color and monochrome, with resolutions from VGA up to 5 megapixels. To meet the highest requirements in the industry, the Stingray comes optionally in a version with a copper daisy chain connection or 1 x copper combined with 1 x GOF connector (2 x optical fiber on LCLC). The camera is loaded with typical AVT intelligent functions for image pre-processing, like lookup tables, shading corrections, white balance and 2 to 8x binning* for enhanced photosensitivity. Grabber functions, including an internal memory and deferred transport mode, make the Stingray ideal for multi-camera operations, while the sequence mode enables lightning-fast parameter changes. The Stingray is designed to be modular and flexible, offering a wide selection of lens-mounts, sensors, case variations, interfaces and cable outputs, which can be flexibly configured using building-block principles.

* monochrome versions only

Highlights

- IEEE 1394b (S 800 daisy chain)
- 2452 (H) X 2056 (V)
- Up to 9 fps (full resolution)
- Progressive scan CCD, monochrome and color
- Image pre-processing features:
 - LUT
 - Real-time shading correction
 - High SNR mode
 - Hue, saturation
 - Color debayering
 - 2x ... 8x binning* / sub-sampling
 - Auto gain, exposure, white balance
 - And lots more ...
- Smart frame grabber features:
 - 32 MB on-board
 - Deferred image transport
 - Trigger delay
 - Multi-shot, mirror image
 - SIS (secure image signature)
 - Sequence mode, user sets
 - And lots more ...
- Industry proven and robust housing
- C-Mount / optional: CS-Mount
- Angled head, board level version (on request), peltier cooling device (soon)
- Medical design on request

++ PRELIMINARY ++

AVT Stingray F-504B / F-504C
AVT Stingray F-504B / F-504C fiber

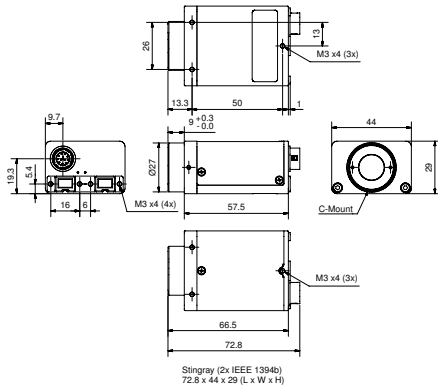

Copper / Daisy Chain



Copper / GOF connections

AOI height / pixel	Frame rate / fps
2054	9
1024	15
960	16
768	18
480	23
240	31
120	37
30	43
10	45
2	46

Pin	Signal
1	External Ground
2	External Power (+8 ... +36 V DC)
3	GP Output 4 (Default: -)
4	GP Input 1 (Default: Trigger)
5	GP Output 3 (Default: Busy)
6	GP Output 1 (Default: IntEna)
7	Input Ground
8	RxD RS232
9	TxD RS232
10	Output Power (max. 36 V DC)
11	GP Input 2 (Default: -)
12	GP Output 2 (Default: Follow GP Input 2)

Dimensions

Camera Specifications

	Stingray F-504 B/C	Stingray F-504 B/C fiber
Image device	Type 2/3 (diag. 11 mm), progressive scan CCD, SONY ICX 655	
Picture size	2452 (H) x 2056 (V)	
Cell size	3.45 µm x 3.45 µm	
Resolution depth	8 bit / 14 bit (16 bit in High SNR mode)	
Lens mount	C-Mount / optional: CS-Mount	
Digital interface	IEEE1394b, (IIC V1.31) S 800 daisy chain	
Transfer rate	100 Mbit/s, 200 Mbit/s, 400 Mbit/s, 800 Mbit/s	
Frame rates	Up to 9 fps (full resolution)	
Gain control	Manual: 0...24 dB, auto gain	
Shutter speed	42 µs ... ~ 67 s, auto shutter	
Image pre-processing	LUT; shading correction; High SNR mode; white balance; color interpolation (debayering); local color anti aliasing; hue; saturation; sub-sampling; 2x - 8x binning (only b/w; F-201C: only 2x) or sub-sampling; separate reference AOI for auto features	
Grabber features	32 MB on-board memory; deferred image transport; trigger delay; multi-shot; mirror image; several trigger modes; SIS (secure image signature); sequence mode; storable user sets	
Power requirements	DC 8 V - 36 V; < 3.9 W @ 12 V	
Dimensions	72.8 mm x 44 mm x 29 mm (L x W x H)	
Mass	92 g (without lens)	
Operating temperature	+ 5 ... + 45° Celsius	
Storage temperature	- 10 ... + 60 ° Celsius	
Regulations	CE, FCC Class B, RoHS (2002/95/EC)	
Options	Angled head, board level version (on request), peltier cooling device (soon), cables, optical filters, medical design on request; AVT FirePackage / Active FirePackage / Fire4Linux	